

# GloEn-Patrol™ Ballast System

## Model : GloEn-P250

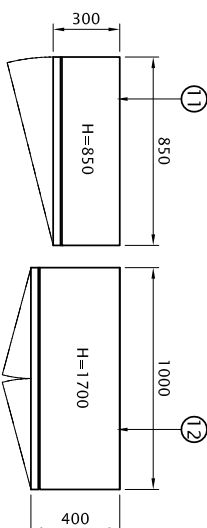
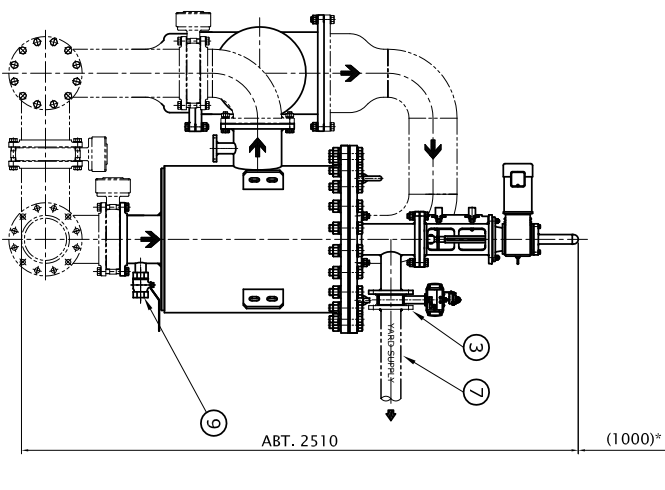
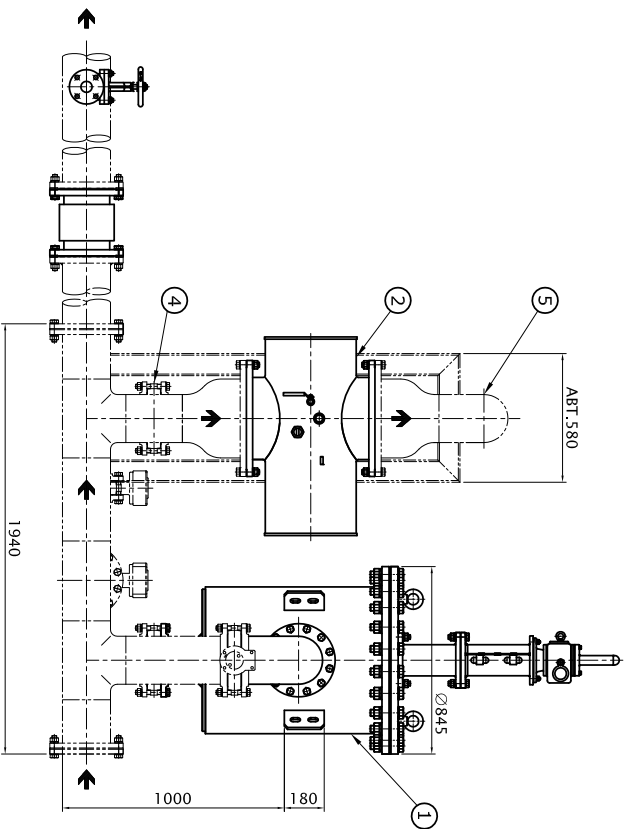
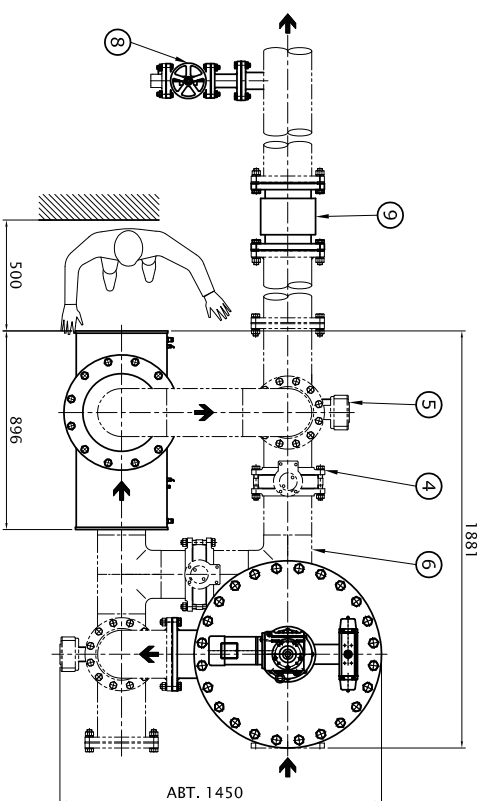

※Specification

Capacity : 250 m<sup>3</sup>/h  
 Filtration degree : 50 micron  
 Fluid : ballast water  
 Power supply : 440VAC 3phase 60Hz  
 220VAC 1 phase 60Hz

12	BALLAST PANEL	1	AL			
11	CONTROL PANEL	1	SUS316L			
10	FLOW METER	1	AL			
9	DRAIN VALVE(10K 25A)	1	SUS316L			
8	SAMPLING NOZZLE(10K 50A)	1	SUS316L			
7	PIPE 80A	1	SS400			
6	PIPE 200A	1	SS400			
5	FLOW CONTROL V/V(W200A)	1	FC			YARD SUPPLY
4	AUTO BUTTERFLY V/V(W200A)	4	FC			YARD SUPPLY
3	BACK FLUSHING V/V	1	FC			
2	UV UNIT	1	SUS316L			
1	FILTER UNIT	1	SUS316L			
NO.	DESCRIPTION	Q'TY	MAT'L	REMARK		
SCALE	ANGLE	UNIT	DATE	DRAWN	CHK'D	APP'D
N/S	3rd	mm	2010.10.25	C.S.PARK	T.S.PVO	T.S.PVO

PROJECT REFERENCE

TITLE  
Layout of  
GloEn-P250

